



DLC Coated Carbide End Mills for Copper Electrodes

Vol.2

# 銅電極用DLC超硬エンドミル

AE-LNBD-N・AE-CPR-N

ロングネックラジアスタイプ

Long neck radius type: AE-CPR-N

144アイテム追加

144 new items added



**A**  
The A Brand

# 充実したラインナップ全216アイテム

Full lineup of 216 items

## LINE UP ラインナップ

### 高精度仕上げ用2刃ロングネックボールタイプ

2-flute long neck ball type for high precision finishing

#### AE-LNBD-N ..... P.3

- R0.05 ~ R3
- 計**72**アイテム  
72 items in total



### 高能率仕上げ用ロングネックラジアスタイプ **NEW**

Long neck radius type for high-efficiency finishing

#### AE-CPR-N ..... P.11

- $\phi 0.2 \sim \phi 6$
- 計**144**アイテム  
144 items in total

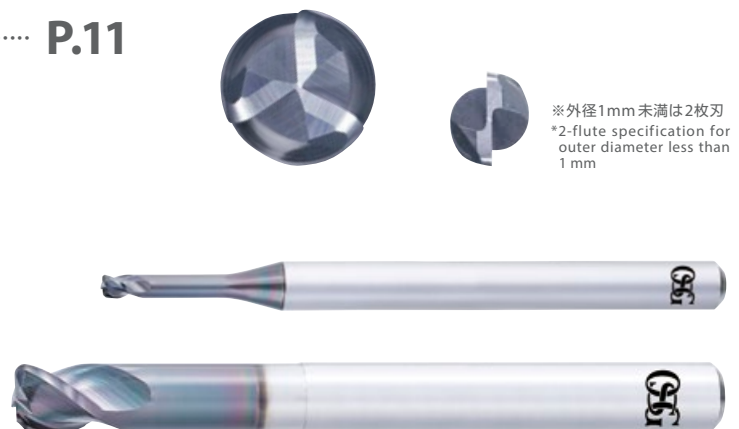

※外径1mm未満は2枚刃  
\*2-flute specification for  
outer diameter less than  
1 mm

# 銅電極加工を一新する独自のDLCコーティング

Unique DLC coating that revamps copper electrode machining

DLCコーティングは表面の平滑さと極めて低い摩擦係数により、耐溶着性や潤滑性が求められる銅合金などの非鉄金属に抜群の威力を発揮します。

Due to its smooth surface and extremely low coefficient of friction, DLC coating is extremely effective against non-ferrous metals such as copper alloys, which require welding resistance and lubricity.

## ■ DLC-IGUSS(アイグス)コーティング DLC-IGUSS Coating

DLC-IGUSSは従来のDLCコーティングと比べて厚膜タイプで刃先の摩耗を抑制し、工具の高い耐久性と良好な加工精度の両立を実現します。

Compared to conventional DLC coating, DLC-IGUSS is a thick film type that suppresses wear on the cutting edge and achieves both high tool durability and good machining accuracy.

コーティングの名称 Name of Coating	被膜色 Coating Color	膜種 Coating Type	硬さ (GPa) Hardness	酸化開始温度(°C) Oxidation Temperature	摩擦係数 Coefficient of Friction	標準膜厚 ( $\mu$ m) Coating Thickness	成膜温度 (°C) Coating Temperature	面粗さ Surface Roughness	耐摩耗性 Wear Resistance	耐溶着性 Welding Resistance	じん性 Toughness
DLC-IGUSS	干渉色 Interference Color	DLC (SP <sup>3</sup> リッチ) SP <sup>3</sup> Rich	60	550	0.10	0.8	400	☆	◎	☆	○

(標準) ○ → ◎ → ☆ (高評価)  
(Good) (Best)

## ■ 耐摩耗性 Wear Resistance

DLC-IGUSSはタフピッチ銅(C1100)に対して摩耗抑制に効果があり、長時間安定した加工精度が得られます。

DLC-IGUSS is effective in suppressing wear against tough-pitch copper (C1100), and stable machining accuracy can be obtained for a long period of time.

使用工具 Tool	2刃超硬ボールエンドミル R1.5 2-flute Carbide Ball End Mill
被削材 Work Material	C1100
加工方法 Milling Method	ピック加工 Pick Milling
切削速度 Cutting Speed	141 m/min (15,000min <sup>-1</sup> )
送り速度 Feed	1,500 mm/min (0.05mm/t)
切込深さ Depth of Cut	$a_p = 1.5\text{mm}$ $P_f = 0.05\text{mm}$
切削油剤 Coolant	水溶性切削油剤 Water-soluble
使用機械 Machine	立形マシニングセンタ (BT40) Vertical Machining Center

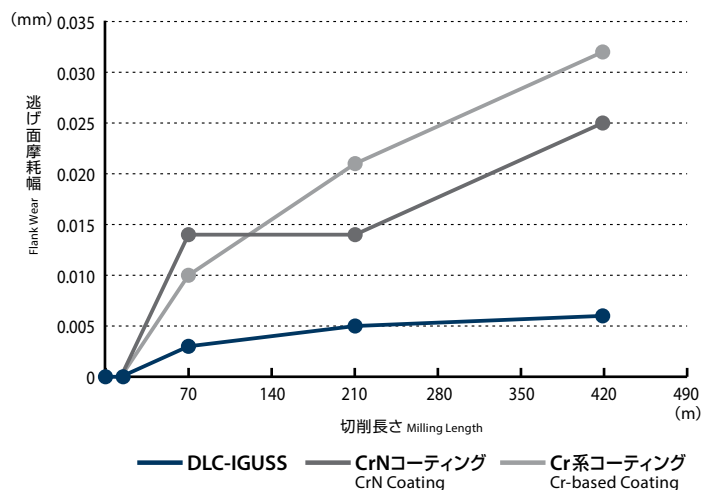

### 420m 加工後のボール部逃げ面摩耗状態

Wear condition of ball flank after milling 420m



高精度仕上げ用2刃ロングネックボールタイプ  
2-flute high-precision finishing long neck ball type

# AE-LNBD-N

## バリのない美しい銅電極を削り出す!

Milling beautiful copper electrodes without burrs!

### 良好な加工面精度

Excellent machined surface accuracy

### バリのない綺麗なエッジ

Beautiful edge without burrs

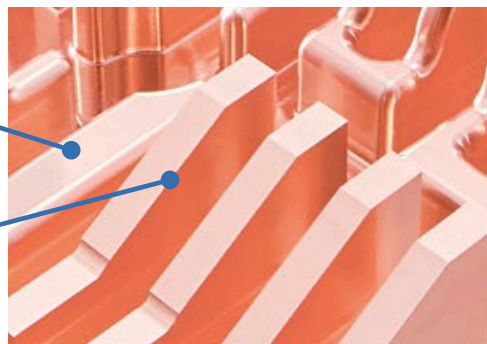

加工詳細はP.5へ  
See page 5 for cutting data



## 高品位な加工を実現するボール部

Ball specifications that enable high quality milling

### ・銅合金加工に最適な鋭い切れ刃形状

・ Optimal cutting edge shape for milling copper alloy

### ・優れたボールR精度

・ Superior ball R precision

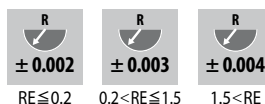

### ・高品位な二番面粗さ

・ High quality primary relief surface

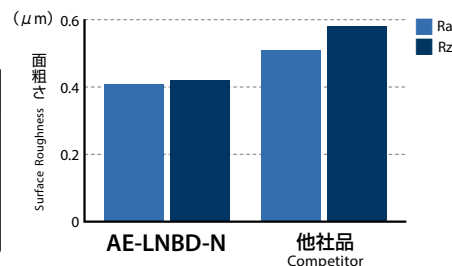
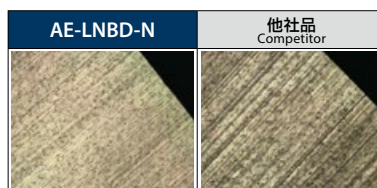

## 外周部ティアドロップ形状

Teardrop-shaped outer periphery

### ・強バックテーパにより点での切削となりびびりが抑制され、欠け防止、加工面精度が向上

・ Strong back taper geometry enables milling by point, which prevents chattering and chipping, resulting in improvement of surface accuracy.

注1：R2以上はティアドロップ形状ではありません  
Note: Teardrop-shaped specification does not apply to items above R2.

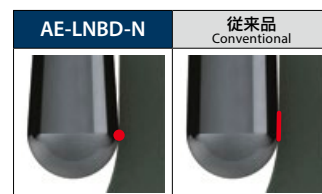

## 優れたシャンク精度

Superior shank accuracy

### ・h4公差 (0/-0.004) に対応

・ Supports h4 tolerance (0/-0.004).



# DLC-IGUSSコーティング採用で圧倒的な長寿命

Overwhelmingly long tool life with DLC-IGUSS coating

工具の長寿命化は廃棄物の削減につながり省資源化に貢献します。  
また長寿命化は工具交換時間の削減により消費電力削減を実現します。

Extension of tool life leads to waste reduction and contributes to resource conservation.  
In addition, longer tool life reduces power consumption by reducing tool change time.

DLC-IGUSSコーティング採用で長寿命化を実現します。DLC-IGUSS coating is used to enable long tool life.

使用工具 Tool	AE-LNBD-N R1×10×4
被削材 Work Material	C1100
加工方法 Milling Method	ピック加工 Pick Milling
切削速度 Cutting Speed	126m/min (20,000min <sup>-1</sup> )
送り速度 Feed	2,000mm/min (0.05mm/t)
切込深さ Depth of Cut	ap=0.2mm (0.1D) Pf=0.4mm (0.2D)
切削油剤 Coolant	水溶性切削油剤 Water-soluble
使用機械 Machine	立形マシニングセンタ (BT40) Vertical Machining Center

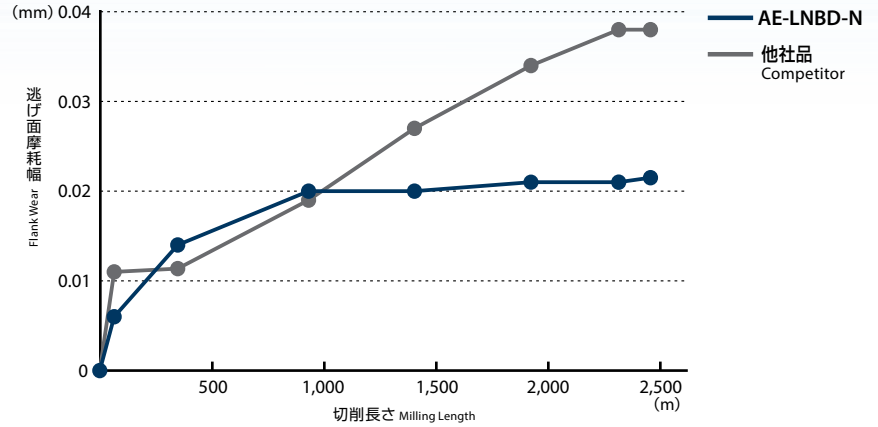

2,480m加工後のボール部逃げ面摩耗状態  
Wearing condition of ball flank after milling 2,480m

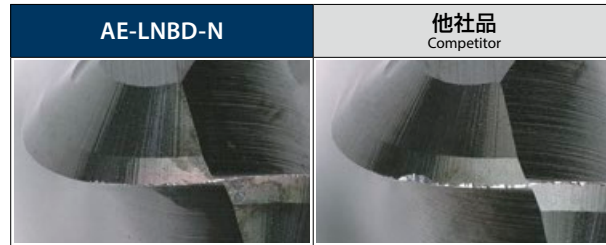

銅タングステンにおいても優れた耐久性を発揮 Exhibits superior endurance in copper tungsten

使用工具 Tool	AE-LNBD-N R1×10×4
被削材 Work Material	銅タングステン Copper Tungsten
加工方法 Milling Method	ピック加工 Pick Milling
切削速度 Cutting Speed	101m/min (16,000min <sup>-1</sup> )
送り速度 Feed	1,400mm/min (0.04mm/t)
切込深さ Depth of Cut	ap=0.2mm (0.1D) Pf=0.4mm (0.2D)
切削油剤 Coolant	水溶性切削油剤 Water-soluble
使用機械 Machine	立形マシニングセンタ (BT40) Vertical Machining Center

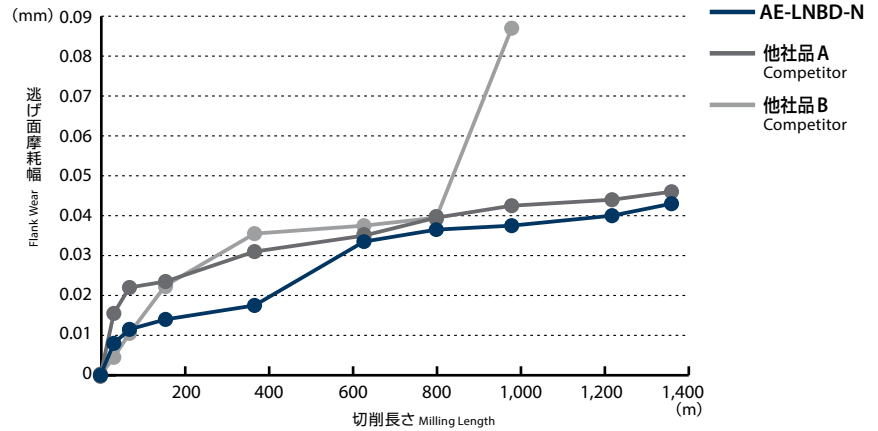

ボール部逃げ面摩耗状態  
Wear condition of ball flank



# 従来品と比較し、バリのない良好な加工面を実現

Achieves good machined surface without burrs compared to conventional products

**被削材：タフピッチ銅 (C1100)**

Work Material : Tough-Pitch Copper

**加工サイズ：60×60 (加工深さ10mm)**

Work Size Milling Depth

**使用機械：立形マシニングセンター (HSK-E32)**

Machine : Vertical Machining Center

**切削油剤：MQL\***

Coolant



\*動画撮影のためMQLを使用  
MQL is used for filming purposes

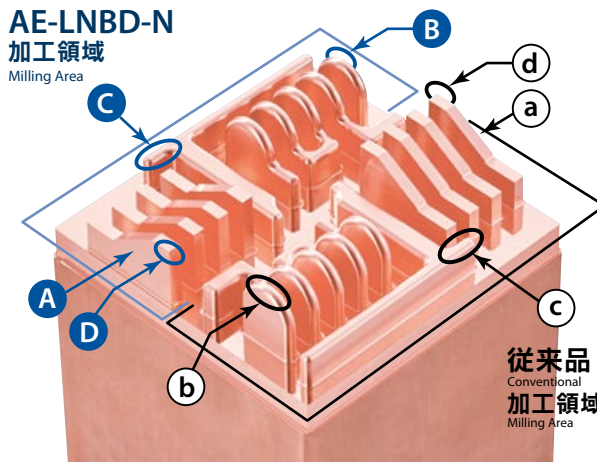

使用工具 Tool	工程番号 Process	加工面状態 Condition of Machined Surface			バリの状態 Condition of Burrs
AE-LNBD-N R1×10×4	⑤	 Ra : 0.1125μm	 むしれ Tear		
従来品 Conventional (Cr系コーティング) (Cr-based Coating) R1×10×4	⑥	 Ra : 0.19125μm	 むしれ Tear	 形状の崩れ Collapse of Shape	 バリ Burrs

工程番号 Process	加工部 Milling Part	加工内容 Milling Process	使用工具 Tool	切削速度 Cutting Speed (m/min)	送り速度 Feed (mm/min)	ap (mm)	Pf (mm)
①	全体 Overall	等高線 Contouring Line ロング刃高能率荒加工 Long Flute High Efficiency Roughing	AE-TL-N 3×15	50 (5,300min <sup>-1</sup> )	600 (0.038mm/t)	11	0.3
②	全体 Overall	等高線 Contouring Line 荒取り加工 Roughing	AE-LNBD-N R1×10×4	105 (16,800min <sup>-1</sup> )	1,500 (0.045mm/t)	0.25	0.25
③	平面部 Surface Plane	正面切削 Frontal Milling 中荒加工 Semi-roughing	AE-TL-N 3×15	50 (5,300min <sup>-1</sup> )	400 (0.025mm/t)	0.1	1
④	全体 Overall	等高線 Contouring Line 中仕上げ加工 Semi-finishing	AE-LNBD-N R1×10×4	105 (16,800min <sup>-1</sup> )	1,500 (0.045mm/t)	0.25	0.25
⑤	左側形状部 Left Shape	等高線 Contouring Line 高精度仕上げ加工 High-precision Finishing	AE-LNBD-N R1×10×4	127 (20,160min <sup>-1</sup> )	750 (0.019mm/t)	0.03	0.03
⑥	右側形状部 Right Shape	等高線 Contouring Line 高精度仕上げ加工 High-precision Finishing	従来品 Conventional (Cr系コーティング) (Cr-based Coating) R1×10×4	127 (20,160min <sup>-1</sup> )	750 (0.019mm/t)	0.03	0.03



# 従来品と比較し、安定した摩耗推移と加工精度を実現

Achieves consistent tool wear over time and machining accuracy compared to conventional products

動画は  
こちらから  
Watch it in action



①、②の各被削材は、以下の切削条件にて加工を行っています

Work materials of ① and ② are processed under the following cutting conditions

協力：碌々スマートテクノロジー株式会社  
Cooperation: ROKU-ROKU SMART TECHNOLOGY CO.,LTD.

使用工具 Tool	AE-LNBD-N R0.2×1×4	従来品 Conventional (Cr系コーティング) Cr-based Coating
被削材 Work Material	①銅タングステン Copper Tungsten	②タフピッチ銅 (C1100) Tough-Pitch Copper
加工方法 Milling Method	等高線 高精度仕上げ加工 Contour and High Precision Finishing	
切削速度 Cutting Speed	Vc=75 m/min (60,000min <sup>-1</sup> )	
送り速度 Feed	Vf=600 mm/min (0.005mm/t)	
切込深さ Depth of Cut	ap = 0.005mm Pf= 0.005mm	
切削油剤 Coolant	不水溶性切削油剤 Non-water-soluble	
使用機械 Machine	Android II (HSK-E25)	

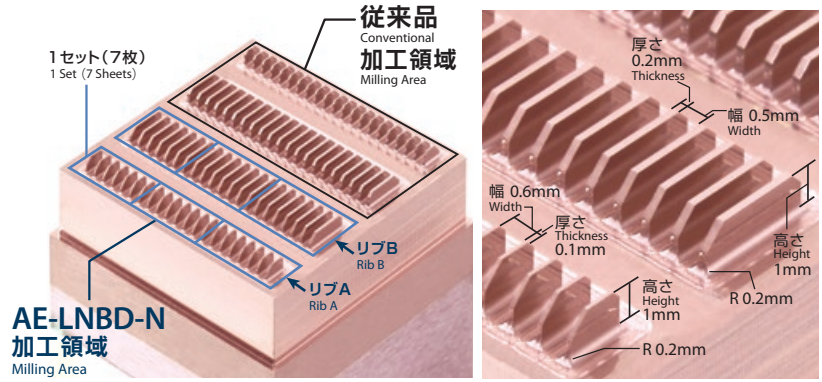

加工サイズ：19×19 (加工深さ1mm)  
Work Size Milling Depth

拡大写真  
Enlarged Photo

## 加工形状 Work Shape

### ①銅タングステンの加工 Machining Copper Tungsten

安定した摩耗推移  
Stable wear transition

52.1m 加工時点での摩耗状態  
Wear comparison after milling 52.1 m

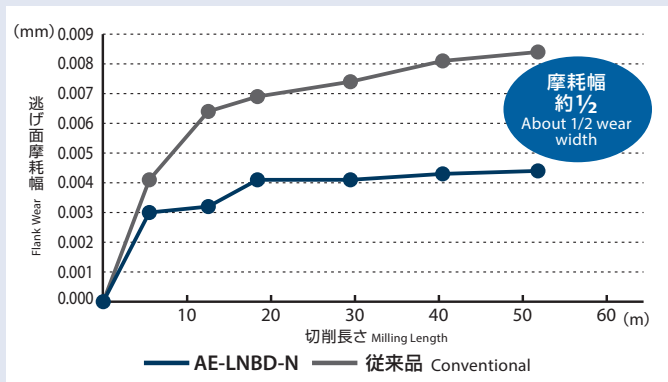
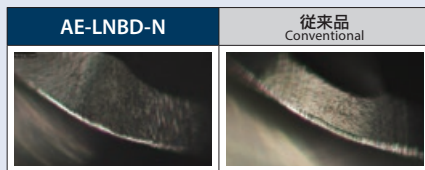

摩耗幅  
約1/2  
About 1/2 wear  
width

### ②タフピッチ銅 (C1100) の加工 Machining Tough-Pitch Copper

バリのない良好なエッジ  
Good edge without burrs



寸法変化の少ない安定した加工精度 Stable machining accuracy with little dimensional change

#### 切削試験評価方法 Evaluation method of cutting test

- ① タフピッチ銅のリブ1セット(7枚)を加工  
Milling 1 set of tough-pitch copper ribs (7 sheets)
- ② リブ1セット加工ごとに寸法測定用銅合金を加工し、寸法測定  
Dimensional measurement by processing a copper alloy block for dimensional measurement of each set of ribs

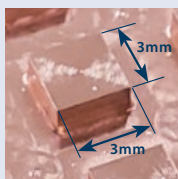

寸法測定用銅合金の形状  
Block of copper alloy for dimensional measurement

リブ1セットの切削長 Cutting length of 1 set of ribs	
リブA Rib A	リブB Rib B
6.2m/1セット set	11.1m/1セット set

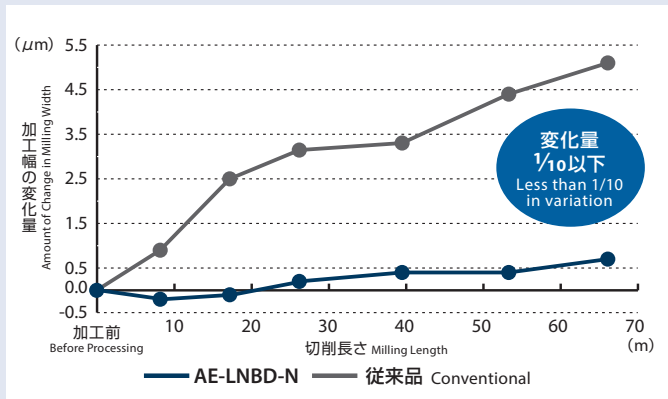

変化量  
1/10以下  
Less than 1/10  
in variation

# AE-LNBD-N

CARBIDE	DLC+GUSS	$\pm 0.002$	$\pm 0.003$	$\pm 0.004$	SHANK h4	SHRINK FIT	30°	SPEED FEED P9~P10
		RE $\leq$ 0.2	0.2<RE $\leq$ 1.5	1.5<RE				

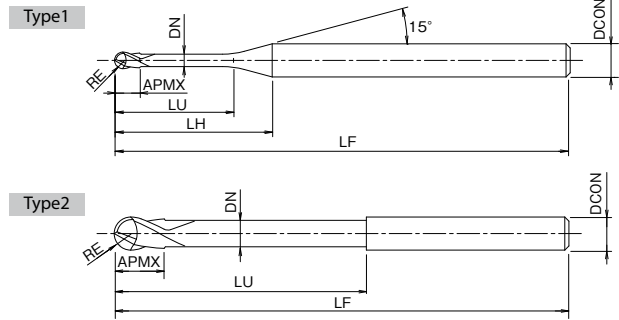

コーティングに色むらが発生する場合がありますが、性能上は全く問題ありません。

End mills may have some discoloration, but it does not cause any performance problems.

単位:mm Unit:mm

ツールNo. EDP No.	ボール半径×首下長×シャンク径 RE × LU × DCON	全長 LF	刃長 APMX	LH	首径 DN	干渉角度 $\theta_k$	ワーク勾配角 $\alpha$ に対する実有効長 $L_e$ 注1 Effective length by inclined angles					形状 Type	在庫 Stock	標準価格 (Yen)	
							0.5°	1°	1.5°	2°	3°				
3056370	R0.05 × 0.3 × 4	45	0.08	7.6	0.09	14.52°	0.3	0.31	0.32	0.33	0.36	1	A	●	8,390
3056371	R0.05 × 0.5 × 4			7.8		14.07°	0.53	0.56	0.59	0.62	0.67			●	9,100
3056372	R0.075 × 0.3 × 4	45	0.12	7.5	0.135	14.55°	0.3	0.31	0.32	0.33	0.35	1	A	●	9,300
3056373	R0.075 × 0.5 × 4			7.7		14.12°	0.52	0.55	0.58	0.6	0.65			●	9,950
3056374	R0.075 × 1 × 4			8.2		13.29°	1.05	1.1	1.14	1.18	1.27			●	10,300
3056375	R0.1 × 0.3 × 4	45	0.16	7.4	0.19	14.59°	0.3	0.31	0.32	0.33	0.34	1	A	●	6,950
3056376	R0.1 × 0.5 × 4			7.6		14.12°	0.53	0.56	0.58	0.61	0.66			●	6,950
3056377	R0.1 × 1 × 4			8.1		13.28°	1.06	1.11	1.15	1.19	1.28			●	6,950
3056378	R0.1 × 1.5 × 4			8.6		12.53°	1.58	1.65	1.7	1.76	1.9			●	7,600
3056379	R0.15 × 0.6 × 4	45	0.24	7.5	0.285	14.02°	0.63	0.65	0.68	0.7	0.75	1	A	●	6,950
3056380	R0.15 × 1 × 4			7.9		13.33°	1.05	1.09	1.13	1.17	1.25			●	6,950
3056381	R0.15 × 1.5 × 4			8.4		12.56°	1.57	1.63	1.68	1.74	1.87			●	7,440
3056382	R0.15 × 2 × 4			8.9		11.87°	2.09	2.16	2.24	2.32	2.49			●	7,440
3056383	R0.2 × 1 × 4	45	0.3	7.7	0.38	13.38°	1.04	1.08	1.11	1.15	1.23	1	A	●	6,200
3056384	R0.2 × 2 × 4			8.7		11.87°	2.08	2.15	2.22	2.3	2.47			●	6,360
3056385	R0.2 × 3 × 4			9.7		10.66°	3.12	3.22	3.33	3.45	3.71			●	7,060
3056386	R0.2 × 4 × 4			10.7		9.68°	4.15	4.29	4.44	4.6	4.95			●	7,700
3056387	R0.25 × 1 × 4	45	0.4	7.6	0.475	13.43°	1.03	1.07	1.1	1.13	1.2	1	A	●	6,100
3056388	R0.25 × 2 × 4			8.6		11.87°	2.07	2.14	2.21	2.28	2.45			●	6,100
3056389	R0.25 × 3 × 4			9.6		10.63°	3.11	3.21	3.32	3.43	3.69			●	6,100
3056390	R0.25 × 4 × 4			10.6		9.63°	4.14	4.28	4.42	4.58	4.93			●	6,100
3056391	R0.25 × 5 × 4			11.6		8.79°	5.18	5.35	5.53	5.73	6.18			●	6,250
3056392	R0.3 × 1 × 4	45	0.5	7.3	0.55	13.5°	1.02	1.05	1.07	1.1	1.17	1	A	●	5,220
3056393	R0.3 × 2 × 4			8.3		11.89°	2.06	2.12	2.18	2.25	2.41			●	4,680
3056394	R0.3 × 3 × 4			9.3		10.62°	3.09	3.19	3.29	3.4	3.66			●	4,840
3056395	R0.3 × 4 × 4			10.3		9.59°	4.12	4.26	4.4	4.55	4.9			●	4,970
3056396	R0.3 × 5 × 4			11.3		8.74°	5.16	5.33	5.51	5.7	6.14			●	4,970
3056397	R0.3 × 6 × 4			12.3		8.02°	6.19	6.4	6.62	6.85	7.39			●	4,970
3056398	R0.4 × 2 × 4	45	0.6	8	0.75	11.87°	2.05	2.11	2.17	2.24	2.39	1	A	●	4,680
3056399	R0.4 × 3 × 4			9.1		10.53°	3.09	3.18	3.28	3.39	3.63			●	5,030
3056400	R0.4 × 4 × 4			10		9.46°	4.12	4.25	4.39	4.54	4.88			●	5,030
3056401	R0.4 × 6 × 4			12		7.86°	6.19	6.39	6.61	6.84	7.36			●	5,030
3056402	R0.4 × 8 × 4			14		6.72°	8.25	8.53	8.82	9.14	9.85			●	5,030

・アイコンの説明はp.8をご覧ください。 See p.8 for explanation of icons.

● = 標準在庫品 ● = Standard stock item

注1: ワーク勾配角 $\alpha$ に対する実有効長  $L_e$  欄に数値がないものは干渉無しを表します  
Note: If there is no value in the actual effective length ( $L_e$  column) for the work gradient angle  $\alpha$ , it indicates no interference.

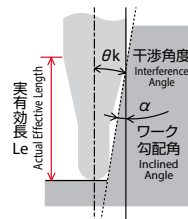

NEXT





## ■ アイコンの種類について Guide for Icons

<b>1 材質</b> Tool Materials <b>CARBIDE</b> 超硬合金 Tungsten Carbide	<b>2 表面処理</b> Surface Treatment <b>DLC-IGUSS</b> DLC-IGUSS コーティング DLC-IGUSS Coating	<b>3 R許容差</b> Tolerance of Radius <b>R ±0.002</b> エンドミルのR許容差を表示します Identifies the tolerance of the radius for end mills	<b>4 外径の許容差</b> Tolerance for milling diameter エンドミルの外径を表示します Tolerance for milling diameter
<b>5 シャンク</b> Shank <b>h4</b> シャンク精度を表示します Tolerance for Shank Diameter	<b>SHRINK FIT</b> シュリンクフィット(焼きばめ)システムにもお奨めします Suitable for the shrink holder system	<b>6 ねじれ角</b> Helix Angle <b>30°</b> エンドミルの溝のねじれ角を表示します Helix angle of flute for end mills	<b>7 切削条件</b> Cutting Conditions <b>SPEED FEED</b> 切削条件基準表掲載ページを表示します Indicates page number for cutting conditions

## FROM

単位:mm Unit:mm

ツールNo. EDP No.	ボール半径×首下長×シャンク径 RE × LU × DCON	全長 LF	刃長 APMX	LH	首径 DN	干渉角度 $\theta_k$	ワーク勾配角 $\alpha$ に対する実有効長 $L_e$ 注1 Effective length by inclined angles					形状 Type	在庫 Stock	標準価格 (Yen)							
							0.5°	1°	1.5°	2°	3°										
3056403	R0.5 × 2 × 4	45	0.8	7.6	0.95	11.85°	2.05	2.1	2.16	2.22	2.37	1	A	●	4,040						
3056404	R0.5 × 3 × 4					10.44°	3.08	3.17	3.27	3.37	3.61			●	4,040						
3056405	R0.5 × 4 × 4					9.32°	4.12	4.24	4.38	4.52	4.85			●	4,450						
3056406	R0.5 × 5 × 4					8.42°	5.15	5.31	5.49	5.67	6.1			●	4,450						
3056407	R0.5 × 6 × 4					7.68°	6.18	6.38	6.59	6.82	7.34			●	4,840						
3056408	R0.5 × 8 × 4					13.6	6.52°	8.25	8.52	8.81	9.12			9.83	●	4,840					
3056409	R0.5 × 10 × 4					15.6	5.67°	10.32	10.66	11.03	11.42			12.31	●	4,840					
3056410	R0.5 × 12 × 4					17.6	5.01°	12.39	12.8	13.24	13.72			14.8	●	4,840					
3056411	R0.75 × 4 × 4					45	1.2	8.8	1.45	8.8°	4.18			4.33	4.46	4.6	4.92	1	A	●	4,660
3056412	R0.75 × 6 × 4									7.09°	6.27			6.47	6.68	6.9	7.4			●	4,660
3056413	R0.75 × 12 × 4	55	16.8	4.46°	12.48					12.89	13.33	13.8	14.86	●	5,620						
3056414	R0.75 × 18 × 4		22.8	3.25°	18.68					19.31	19.98	20.7	22.32	●	5,620						
3056415	R1 × 4 × 4	50	1.6	8.2	1.95	7.88°	4.22	4.44	4.65	4.86	5.26	1	A	●	4,040						
3056416	R1 × 6 × 4					10.2	6.2°	6.35	6.67	6.96	7.23			7.75	●	4,500					
3056417	R1 × 8 × 4					12.2	5.1°	8.47	8.87	9.22	9.54			10.24	●	4,840					
3056418	R1 × 10 × 4					14.2	4.34°	10.58	11.05	11.45	11.84			12.73	●	4,840					
3056419	R1 × 12 × 4					16.2	3.77°	12.68	13.21	13.67	14.14			15.21	●	4,840					
3056420	R1 × 14 × 4					18.2	3.33°	14.78	15.36	15.88	16.44			17.7	●	4,840					
3056421	R1 × 16 × 4					20.2	2.99°	16.87	17.5	18.1	18.74			—	●	4,840					
3056422	R1 × 20 × 4					60	24.2	2.47°	21.04	21.78	22.53			23.34	—	●	4,840				
3056423	R1 × 25 × 4						29.2	2.04°	26.24	27.13	28.07			29.09	—	●	6,750				
3056424	R1.5 × 10 × 6						55	2.4	15.8	2.85	5.95°			10.44	10.83	11.18	11.55	12.37	1	A	●
3056425	R1.5 × 12 × 6	17.8	5.23°	12.53	12.98	13.4					13.85	14.85	●	5,610							
3056426	R1.5 × 14 × 6	19.8	4.67°	14.62	15.12	15.62					16.15	17.34	●	6,530							
3056427	R1.5 × 16 × 6	21.8	4.21°	16.7	17.26	17.83					18.45	19.83	●	6,530							
3056428	R1.5 × 20 × 6	25.8	3.53°	20.85	21.54	22.27					23.05	24.8	●	6,360							
3056429	R1.5 × 25 × 6	65	30.8	2.93°	26.03	26.89					27.81	28.8	—	●	6,360						
3056430	R1.5 × 30 × 6		35.8	2.5°	31.2	32.24					33.35	34.54	—	●	7,170						
3056431	R2 × 10 × 6		60	14	4.75°	10.42					10.79	11.13	11.47	12.25	1	A	●	5,030			
3056432	R2 × 15 × 6	19		3.37°	15.64	16.16					16.67	17.22	18.47	●			6,590				
3056433	R2 × 20 × 6	65	24	2.61°	20.84	21.51					22.21	22.97	—	1	A	●	6,590				
3056434	R2 × 25 × 6		29	2.13°	26.02	26.85	27.75	28.72	—	●	6,590										
3056435	R2 × 30 × 6	80	34	1.79°	31.18	32.2	33.3	—	—	1	A	●	6,590								
3056436	R2 × 40 × 6		44	1.37°	41.52	42.9	—	—	—			●	8,510								
3056437	R3 × 10 × 6		70	—	—	—	—	—	—			—	2	A	●	8,210					
3056438	R3 × 15 × 6	—		—	—	—	—	—	—	●	8,210										
3056439	R3 × 20 × 6	—		—	—	—	—	—	—	●	8,210										
3056440	R3 × 30 × 6	—		—	—	—	—	—	—	●	8,450										
3056441	R3 × 50 × 6	90	—	—	—	—	—	—	—	●	9,960										

● = 標準在庫品 ● = Standard stock item



# AE-LNBD-N 切削条件基準表 Cutting Condition

**⚠** 加工時に発生する火花や破損による発熱で引火・火災の危険があります。  
防火対策を必ず行って下さい。

**Caution :** Sparks generated during operation or heat caused by tool breakage can cause fire.  
Be sure to use all proper fire-prevention measures.

被削材 Work Material		銅 Copper (C1020,C1100)				銅タングステン Copper Tungsten (W70% - Cu30%)			
RE	首下長 LU (mm)	回転速度 Speed (min <sup>-1</sup> )	送り速度 Feed (mm/min)	切込み深さ (mm) Depth of cut		回転速度 Speed (min <sup>-1</sup> )	送り速度 Feed (mm/min)	ap	Pf
				ap	Pf				
R0.05	0.3	38,400	225	0.005	0.01	32,000	120	0.005	0.008
	0.5	38,400	180	0.005	0.01	32,000	96	0.005	0.008
R0.075	0.3	38,400	257	0.008	0.02	32,000	137	0.008	0.015
	0.5	38,400	225	0.008	0.02	32,000	120	0.008	0.021
	1	38,400	180	0.005	0.01	32,000	96	0.005	0.011
R0.1	0.3	38,400	450	0.02	0.04	32,000	240	0.02	0.03
	0.5	38,400	450	0.02	0.04	32,000	240	0.02	0.03
	1	38,400	225	0.02	0.04	32,000	120	0.02	0.03
	1.5	38,400	225	0.02	0.04	32,000	120	0.02	0.03
R0.15	0.6	38,400	900	0.02	0.06	32,000	480	0.02	0.045
	1	38,400	675	0.02	0.06	32,000	360	0.02	0.045
	1.5	38,400	675	0.02	0.06	32,000	360	0.02	0.045
	2	38,400	675	0.02	0.06	32,000	360	0.02	0.045
R0.2	1	38,400	900	0.025	0.1	32,000	480	0.025	0.075
	2	32,400	675	0.025	0.1	27,000	360	0.025	0.075
	3	32,400	675	0.025	0.1	27,000	360	0.025	0.075
	4	32,400	675	0.01	0.06	27,000	360	0.01	0.045
R0.25	1	38,400	1,125	0.04	0.1	32,000	600	0.04	0.075
	2	38,400	900	0.04	0.1	32,000	480	0.04	0.075
	3	32,400	675	0.04	0.1	27,000	360	0.04	0.075
	4	32,400	675	0.04	0.1	27,000	360	0.04	0.075
	5	25,200	450	0.04	0.1	21,000	240	0.04	0.075
R0.3	1	38,400	2,250	0.09	0.12	32,000	1,440	0.08	0.12
	2	38,400	1,688	0.09	0.12	32,000	1,080	0.08	0.12
	3	36,000	938	0.09	0.12	30,000	600	0.08	0.12
	4	36,000	938	0.09	0.12	30,000	600	0.08	0.12
	5	36,000	938	0.09	0.12	30,000	600	0.08	0.12
	6	30,000	563	0.09	0.12	25,000	360	0.08	0.12
R0.4	2	32,400	1,688	0.12	0.16	27,000	1,080	0.11	0.16
	3	32,400	1,688	0.12	0.16	27,000	1,080	0.11	0.16
	4	32,400	1,688	0.12	0.16	27,000	1,080	0.11	0.16
	6	28,800	938	0.12	0.12	24,000	600	0.11	0.12
	8	26,400	563	0.12	0.12	22,000	360	0.11	0.12

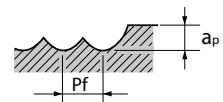

1. 機械、ホルダは剛性のある精度の高いものをご使用下さい。
2. 切込深さ、機械剛性等使用状況により、回転速度、送り速度を調整ください。
3. 水溶性切削油剤をご使用下さい。
4. 加工面、精度を重視される場合は、不水溶性切削油剤をご使用ください。切込深さ、送り速度を必要に応じて調整下さい。
5. 切削油剤は切削油剤メーカーの推奨するものを必ずご使用下さい。加工物が変色することがあります。

**NEXT**



FROM

被削材 Work Material		銅 Copper (C1020,C1100)				銅タングステン Copper Tungsten (W70% - Cu30%)			
RE	首下長 LU (mm)	回転速度 Speed (min <sup>-1</sup> )	送り速度 Feed (mm/min)	切込み深さ (mm) Depth of cut		回転速度 Speed (min <sup>-1</sup> )	送り速度 Feed (mm/min)	ap	Pf
				ap	Pf				
R0.5	2	33,600	1,875	0.15	0.2	28,000	1,200	0.14	0.2
	3	33,600	1,875	0.15	0.2	28,000	1,200	0.14	0.2
	4	33,600	1,875	0.15	0.2	28,000	1,200	0.14	0.2
	5	25,200	1,125	0.15	0.2	21,000	720	0.14	0.2
	6	25,200	1,125	0.15	0.2	21,000	720	0.14	0.2
	8	25,200	1,125	0.15	0.15	21,000	720	0.14	0.15
	10	21,600	750	0.12	0.12	18,000	480	0.11	0.12
	12	21,600	750	0.12	0.12	18,000	480	0.11	0.12
R0.75	4	24,000	2,250	0.24	0.3	20,000	1,440	0.22	0.3
	6	21,600	1,875	0.24	0.3	18,000	1,200	0.22	0.3
	12	20,400	1,125	0.24	0.24	17,000	720	0.22	0.24
	18	15,600	750	0.18	0.18	13,000	480	0.16	0.18
R1	4	19,800	2,625	0.3	0.56	16,500	1,680	0.27	0.56
	6	19,800	2,625	0.3	0.56	16,500	1,680	0.27	0.56
	8	19,800	2,625	0.3	0.56	16,500	1,680	0.27	0.56
	10	16,800	1,875	0.3	0.56	14,000	1,200	0.27	0.56
	12	16,800	1,875	0.3	0.56	14,000	1,200	0.27	0.56
	14	16,800	1,875	0.3	0.56	14,000	1,200	0.27	0.56
	16	16,800	1,875	0.3	0.42	14,000	1,200	0.27	0.42
	20	13,200	938	0.3	0.42	11,000	600	0.27	0.42
	25	13,200	938	0.3	0.42	11,000	600	0.27	0.42
R1.5	10	14,400	2,250	0.4	0.84	12,000	1,440	0.36	0.84
	12	12,000	2,250	0.4	0.84	10,000	1,440	0.36	0.84
	14	12,000	2,250	0.4	0.84	10,000	1,440	0.36	0.84
	16	12,000	1,125	0.4	0.84	10,000	720	0.36	0.84
	20	12,000	1,125	0.4	0.84	10,000	720	0.36	0.84
	25	12,000	1,125	0.4	0.84	10,000	720	0.36	0.84
	30	10,800	938	0.4	0.84	9,000	600	0.36	0.84
R2	10	10,800	3,000	1.0	1.3	9,000	1,920	0.9	1.3
	15	10,800	2,250	1.0	1.3	9,000	1,440	0.9	1.3
	20	8,400	1,500	1.0	1.3	7,000	960	0.9	1.3
	25	8,400	1,500	1.0	1.3	7,000	960	0.9	1.3
	30	8,400	1,500	0.8	1.3	7,000	960	0.7	1.3
	40	6,000	938	0.7	1.3	5,000	600	0.6	1.3
R3	10	10,800	3,375	1.2	1.8	9,000	2,160	1.1	1.8
	15	10,800	3,375	1.2	1.8	9,000	2,160	1.1	1.8
	20	8,400	1,875	1.2	1.8	7,000	1,200	1.1	1.8
	30	7,200	1,875	1.2	1.8	6,000	1,200	1.1	1.8
	50	6,000	1,125	0.8	1.8	5,000	720	0.7	1.8

1. Use a rigid and precise machine and holder.
2. Please adjust the speed and feed when the cutting depth is large or when machines with low rigidity are used.
3. Use a water soluble fluid.
4. Use a non-water-soluble cutting fluid if the machined surface and accuracy are of critical importance.  
Adjust the depth of cut and feed rate as necessary.
5. Always use a cutting fluid recommended by the cutting fluid manufacturer as the workpiece may discolor.



高能率仕上げ用ロングネックラジアスタイプ  
High-efficiency finishing long neck radius type

# AE-CPR-N

## 高能率・長寿命・高精度加工を実現!

Achieves high efficiency, long tool life and high precision machining!

### 高能率加工を実現する3枚刃仕様\*

Achieves high efficiency milling with 3-flute specification\*

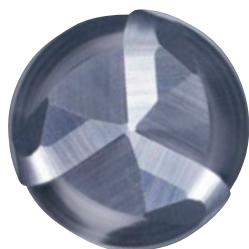

※外径1mm未満は2枚刃  
\*2-flute specification for outer diameter  
less than 1 mm

### さらい刃仕様

Flat cutting edge specification

- 高精度な加工面品位を実現

• Achieves higher precision machined surface quality

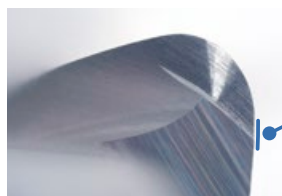

#### さらい刃

Flat cutting edge

※一部サイズを除く  
\*Excluding some sizes

### 優れた刃径精度とコーナR精度

Excellent cutting edge diameter accuracy and superior corner radius precision

- 優れた刃径精度

• Excellent cutting edge diameter accuracy

外径 (DC)  $\phi 1$ 以下 0~-0.006  
Up to  $\phi 1$

$\phi 1$ 超え 0~-0.01  
Over  $\phi 1$



- 優れたコーナR精度

• Superior R precision

全サイズ  $\pm 0.004$   
All sizes



### 豊富なバリエーション

Abundant variations

- 外径0.2mm~6mmと豊富な首下長さ

• Available from outer diameter 0.2 mm to 6 mm with a wide variety of neck lengths





# 高能率・長寿命化を実現

Achieves high efficiency and long tool life



工具の長寿命化は廃棄物の削減につながり省資源化に貢献します。  
 外径1mm以上は3枚刃仕様で加工能率の向上が可能です。  
 高能率加工は機械稼働時間を短縮し消費電力の削減を実現します。

Extension of tool life leads to waste reduction and contributes to resource conservation.  
 Machining efficiency can be improved with the 3-flute specification for outer diameters of 1 mm or more.  
 High-efficiency machining shortens machine operating time and reduces power consumption.

## 3枚刃仕様により高能率加工・長寿命化が可能

3-flute specification enables high-efficiency machining and long tool life

使用工具 Tool	AE-CPR-N φ4×R0.5×16 3刃 3-flute	他社品 2刃 Competitor 2-flute
被削材 Work Material	C1100	
加工方法 Milling Method	正面切削 Frontal Milling	
切削速度 Cutting Speed	126m/min (10,000min <sup>-1</sup> )	
送り速度 Feed	4,200mm/min (0.14mm/t)	2,800mm/min (0.14mm/t)
切込深さ Depth of Cut	ap=0.3mm ae=2.4mm	
切削油剤 Coolant	水溶性切削油剤 Water-soluble	
使用機械 Machine	横形マシニングセンタ (HSK63) Horizontal Machining Center	

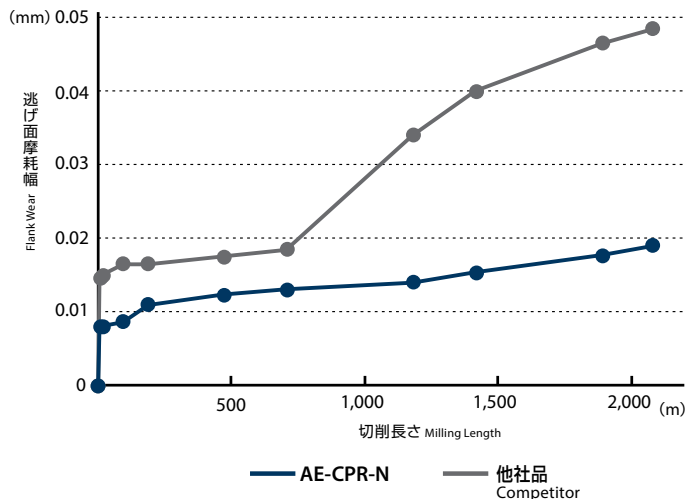

## 2,079m 加工後の刃先の摩耗・加工面状態

Wear condition of the cutting edge after milling 2,079 m

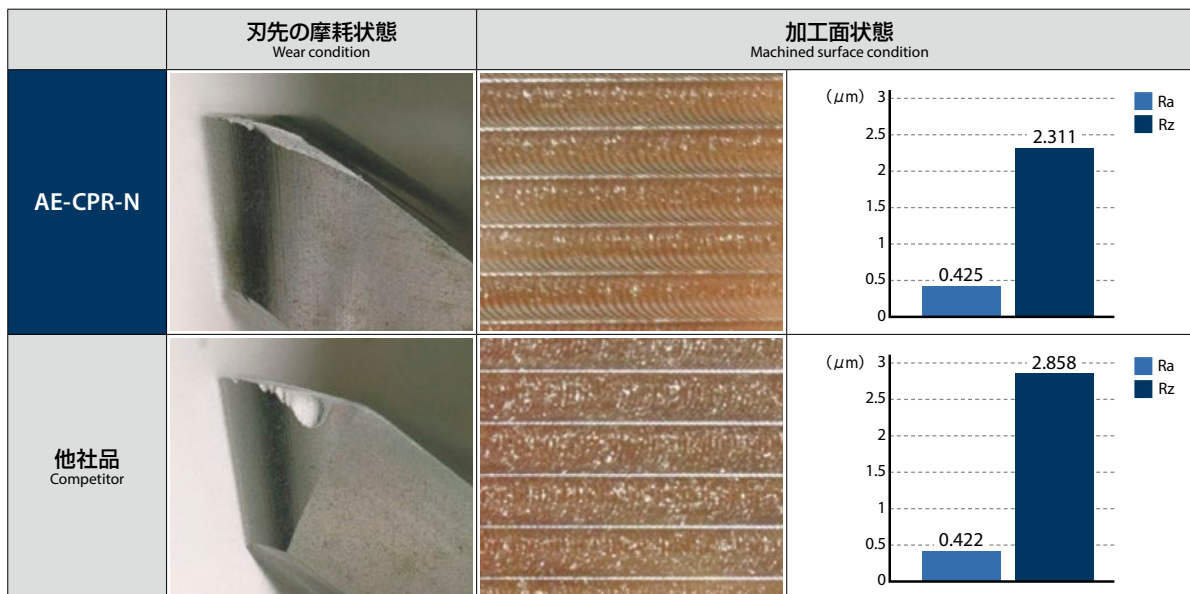

## φ0.5でも安定した摩耗推移

Stable wear transition even at φ0.5

使用工具 Tool	AE-CPR-N 0.5×R0.1×3
被削材 Work Material	C1100
加工方法 Milling Method	正面切削 Frontal Milling
切削速度 Cutting Speed	55m/min (35,000min <sup>-1</sup> )
送り速度 Feed	640mm/min (0.01mm/t)
切込深さ Depth of Cut	ap=0.05mm ae=0.25mm
切削油剤 Coolant	水溶性切削油剤 Water-soluble
使用機械 Machine	立形マシニングセンタ (HSK-E32) Vertical Machining Center

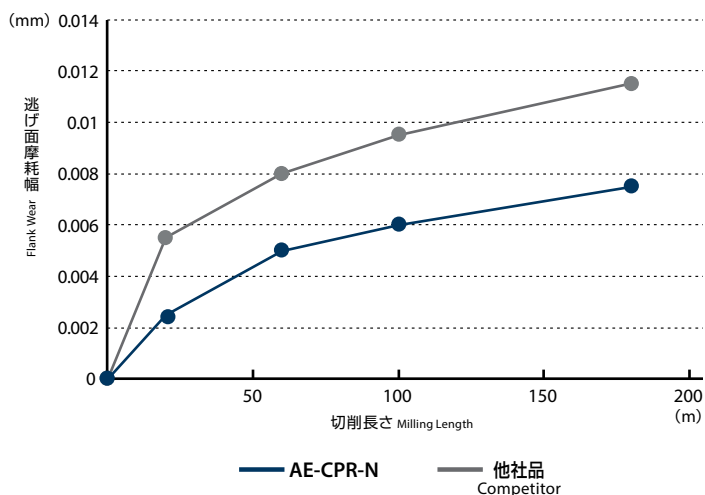

## 銅電極加工に対応可能な非鉄用DLCエンドミルのご紹介

DLC coated end mill lineup for non-ferrous metals compatible with copper electrode applications

製品詳細はこちら  
Scan code for product details



### スタンダード — 非鉄加工に適した標準仕様 —

Standard Standard specification suitable for non-ferrous material processing

#### DLC-SUPER HARDコーティング DLC-SUPER HARD coating

ショート形 Short

1.5D刃長 AE-TS-N  
1.5 × D cutting length



ロング形 Long

3D/5D刃長 AE-TL-N  
3 × D / 5 × D cutting length



### 高機能 — 多様な加工に対応する高機能タイプ —

High Performance High performance type that supports a wide range of applications

#### DLC-IGUSSコーティング DLC-IGUSS coating

ショート形 Short

1.5D刃長 AE-VTS-N  
1.5 × D cutting length



立ち壁対応型 For Deep Side Milling

2.5D刃長 AE-VTFE-N  
2.5 × D cutting length



#### ヘッド交換式エンドミル PXM Exchangeable Head End Mill

1D刃長 PXAL  
1 × D cutting length



# 銅電極を高能率・高精度に加工

Milling copper electrodes with high efficiency and precision

動画は  
こちらから  
Watch it in action



使用工具 Tool	AE-CPR-N 1×R0.2×10	従来品 2枚刃* Conventional 2-flute	他社品 2枚刃 Competitor 2-flute
被削材 Work Material	タフピッチ銅 (C1100) Tough-Pitch Copper		
加工方法 Milling Method	等高線 高精度仕上げ加工 Contour and High Precision Finishing		
切削速度 Cutting Speed	56.5m/min (18,000min <sup>-1</sup> )		
送り速度 Feed	660mm/min (0.012mm/t)	360mm/min (0.01mm/t)	430mm/min (0.012mm/t)
切込深さ Depth of Cut	ap = 0.025mm ae = 0.03mm		
切削油剤 Coolant	水溶性切削油剤 Water-soluble		
使用機械 Machine	立形マシニングセンタ (HSK-E25) Vertical Machining Center		

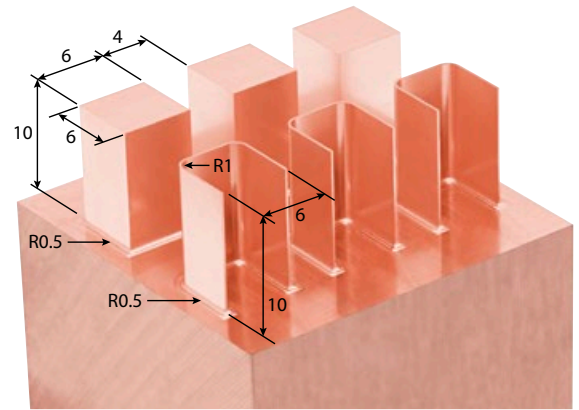

単位:mm Unit:mm

\*鋼用コーティング超硬エンドミル ラジアスタイプ  
\*Coated carbide end mill for steel (radius type)

## 良好な加工精度と加工形状 Good milling accuracy and good processing shape

### ①リブ Rib

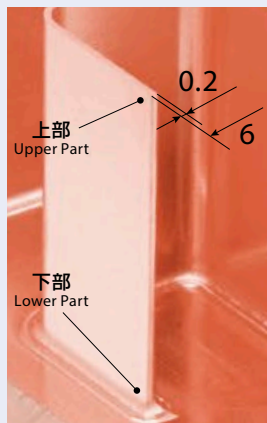

### リブの幅 (狙い値: 0.2 mm) Rib width (target value: 0.2 mm)

測定位置 Measurement Position	加工面の実測値 Measured value of machined surface		
	AE-CPR-N	従来品 Conventional	他社品 Competitor
上部 Upper Part	0.2003mm	0.1946mm	0.2138mm
下部 Lower Part	0.2008mm	0.1953mm	0.2128mm
加工面状態 Condition of Machined Surface			

### ②角柱 Vertex

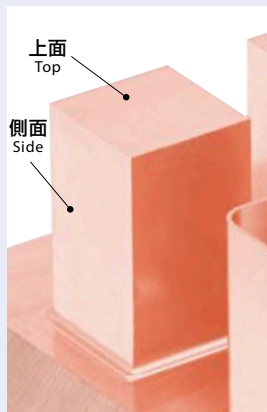

### 加工面粗さ Surface roughness

測定位置 Measurement Position	加工面の実測値 Measured value of machined surface		
	AE-CPR-N	従来品 Conventional	他社品 Competitor
上面 Top	Ra : 0.052μm Rz : 0.664μm	Ra : 0.075μm Rz : 1.390μm	Ra : 0.075μm Rz : 0.563μm
側面 Side	Ra : 0.173μm Rz : 1.279μm	Ra : 0.164μm Rz : 1.239μm	Ra : 0.232μm Rz : 1.438μm
加工形状 Processing Shape			

AE-CPR-Nは崩れの少ない形状が得られた  
The AE-CPR-N exhibited minimal collapse in shape

# AE-CPR-N

CARBIDE **DLC-KGUS**  $\pm 0.004$   $R$  SHANK **h4** SHRINK **FIT** **38°** SPEED FEED **P19~P21**

DC ≤ 1 0 ~ -0.006  
1 < DC 0 ~ -0.01

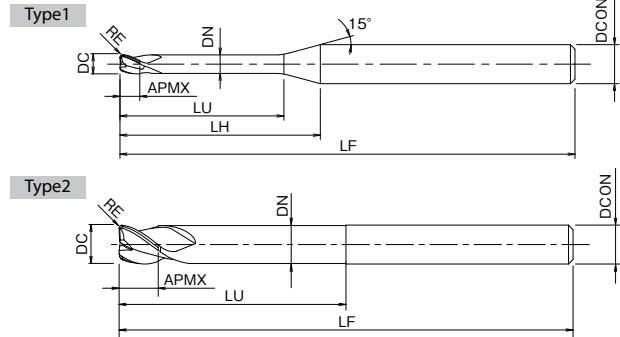

コーティングに色むらが発生する場合がありますが、性能上は全く問題ありません。

End mills may have some discoloration, but it does not cause any performance problems.

単位:mm Unit:mm

ツールNo. EDP No.	外径×コーナ半径×首下長 DC × RE × LU	全長 LF	刃長 APMX	LH	首径 DN	干渉角度 $\theta_k$	シャンク径 DCON	刃数 ZEPF	ワーク勾配角 $\alpha$ に対する実有効長 $L_e$ <sup>注1</sup> Effective length by inclined angles					形状 Type	在庫 Stock	標準価格 (Yen)							
									0.5°	1°	1.5°	2°	3°										
8557646	0.2 × R0.05 × 0.4	45	0.2	7.5	0.175	14.28°	4	2	0.41	0.43	0.45	0.47	0.51	1	A	● 7,710							
8557647	0.2 × R0.05 × 0.6			7.7		13.92°			0.62	0.65	0.68	0.7	0.75			● 7,780							
8557648	0.2 × R0.05 × 1			8.1		13.26°			1.04	1.08	1.12	1.16	1.25			● 8,130							
8557649	0.2 × R0.05 × 1.5			8.6		12.51°			1.56	1.62	1.68	1.74	1.87			● 8,340							
8557650	0.3 × R0.05 × 0.6	45	0.3	7.5	0.275	13.9°	4	2	0.62	0.65	0.68	0.7	0.75	1	A	● 7,920							
8557651	0.3 × R0.05 × 1			7.9		13.22°			1.04	1.08	1.12	1.16	1.25			● 8,130							
8557652	0.3 × R0.05 × 1.5			8.4		12.45°			1.56	1.62	1.68	1.74	1.87			● 8,340							
8557653	0.3 × R0.05 × 2			8.9		11.77°			2.08	2.15	2.23	2.31	2.5			● 8,460							
8557654	0.4 × R0.02 × 0.8	45	0.4	7.5	0.37	13.47°	4	2	0.83	0.86	0.9	0.93	1	1	A	● 7,030							
8557655	0.4 × R0.02 × 2			8.7		11.68°			2.08	2.15	2.23	2.31	2.5			● 7,250							
8557656	0.4 × R0.05 × 0.8			7.5		13.52°			0.83	0.86	0.89	0.92	1			● 7,030							
8557657	0.4 × R0.05 × 1.2			7.9		12.86°			1.25	1.29	1.34	1.38	1.49			● 7,110							
8557658	0.4 × R0.05 × 2			8.7		11.71°			2.08	2.15	2.22	2.3	2.49			● 7,250							
8557659	0.4 × R0.05 × 3			9.7		10.53°			3.11	3.22	3.33	3.45	3.73			● 7,380							
8557660	0.4 × R0.05 × 4			10.7		9.57°			4.14	4.29	4.44	4.6	4.97			● 7,540							
8557661	0.4 × R0.1 × 0.8			7.5		13.6°			0.83	0.86	0.89	0.92	0.98			● 7,030							
8557662	0.4 × R0.1 × 1.2			7.9		12.93°			1.24	1.29	1.33	1.38	1.48			● 7,110							
8557663	0.4 × R0.1 × 2			8.7		11.77°			2.07	2.14	2.22	2.3	2.48			● 7,250							
8557664	0.4 × R0.1 × 3			9.7		10.58°			3.11	3.21	3.33	3.45	3.72			● 7,380							
8557665	0.4 × R0.1 × 4			10.7		9.61°			4.14	4.28	4.43	4.6	4.96			● 7,540							
8557666	0.5 × R0.05 × 1			45		0.5			7.5	0.45	13.16°	4	2			1.03	1.06	1.1	1.14	1.23	1	A	● 6,910
8557667	0.5 × R0.05 × 2								8.5		11.65°					2.06	2.13	2.21	2.29	2.47			● 7,030
8557668	0.5 × R0.05 × 3								9.5		10.45°					3.1	3.2	3.32	3.44	3.72			● 7,200
8557669	0.5 × R0.05 × 4								10.5		9.48°					4.13	4.27	4.43	4.59	4.96			● 7,320
8557670	0.5 × R0.05 × 5	11.5	8.67°		5.16		5.34	5.53	5.74		6.2			● 7,440									
8557671	0.5 × R0.1 × 1	7.5	13.23°		1.03		1.06	1.1	1.13		1.22			● 6,910									
8557672	0.5 × R0.1 × 2	8.5	11.71°		2.06		2.13	2.2	2.28		2.46			● 7,030									
8557673	0.5 × R0.1 × 3	9.5	10.5°		3.1		3.2	3.31	3.43		3.7			● 7,200									
8557674	0.5 × R0.1 × 4	10.5	9.52°		4.13		4.27	4.42	4.58		4.95			● 7,320									
8557675	0.5 × R0.1 × 5	11.5	8.7°		5.16		5.34	5.53	5.73		6.19			● 7,440									

・アイコンの説明はp.8をご覧ください。 See p.8 for explanation of icons.

● = 標準在庫品 ● = Standard stock item





注1: ワーク勾配角 $\alpha$ に対する実有効長  $L_e$  欄に数値がないものは干渉無しを表します  
 Note: If there is no value in the actual effective length ( $L_e$  column) for the work gradient angle  $\alpha$ , it indicates no interference.

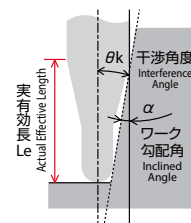

FROM

単位:mm Unit:mm

ツールNo. EDP No.	外径×コーナ半径×首下長 DC × RE × LU	全長 LF	刃長 APMX	LH	首径 DN	干渉角度 $\theta_k$	シャンク径 DCON	刃数 ZEFP	ワーク勾配角 $\alpha$ に対する実有効長 $L_e$ 注1 Effective length by inclined angles					形状 Type	在庫 Stock	標準価格 (Yen)	
									0.5°	1°	1.5°	2°	3°				
8557676	0.6 × R0.05 × 1.2	45	0.6	7.5	0.55	12.77°	4	2	1.24	1.28	1.32	1.37	1.48	1	A	●	7,440
8557677	0.6 × R0.05 × 2			8.3		11.58°			2.06	2.13	2.21	2.29	2.47			●	7,590
8557678	0.6 × R0.05 × 4			10.3		9.38°			4.13	4.27	4.43	4.59	4.96			●	7,920
8557679	0.6 × R0.05 × 6			12.3		7.87°			6.2	6.41	6.64	6.89	7.45			●	8,190
8557680	0.6 × R0.1 × 1.2			7.5		12.84°			1.23	1.27	1.32	1.36	1.47			●	7,440
8557681	0.6 × R0.1 × 2			8.3		11.64°			2.06	2.13	2.2	2.28	2.46			●	7,590
8557682	0.6 × R0.1 × 3			9.3		10.41°			3.1	3.2	3.31	3.43	3.7			●	7,780
8557683	0.6 × R0.1 × 4			10.3		9.42°			4.13	4.27	4.42	4.58	4.95			●	7,920
8557684	0.6 × R0.1 × 6			12.3		7.9°			6.2	6.41	6.64	6.88	7.43			●	8,190
8557685	0.6 × R0.2 × 1.2			7.5		12.99°			1.23	1.27	1.31	1.35	1.44			●	7,440
8557686	0.6 × R0.2 × 4	10.3	9.5°	4.13	4.26	4.41	4.57	4.92	●	7,920							
8557687	0.8 × R0.05 × 1.6	45	0.8	7.6	0.75	12°	4	2	1.65	1.71	1.77	1.83	1.98	1	A	●	7,660
8557688	0.8 × R0.05 × 4			10		9.16°			4.13	4.27	4.43	4.59	4.96			●	7,920
8557689	0.8 × R0.05 × 6			12		7.65°			6.2	6.41	6.64	6.89	7.45			●	8,190
8557690	0.8 × R0.05 × 8			14		6.56°			8.27	8.55	8.86	9.19	9.93			●	8,340
8557691	0.8 × R0.1 × 1.6			7.6		12.07°			1.65	1.7	1.76	1.82	1.96			●	7,660
8557692	0.8 × R0.1 × 4			10		9.2°			4.13	4.27	4.42	4.58	4.95			●	7,920
8557693	0.8 × R0.1 × 6			12		7.67°			6.2	6.41	6.64	6.88	7.43			●	8,190
8557694	0.8 × R0.1 × 8			14		6.58°			8.26	8.55	8.85	9.18	9.92			●	8,340
8557695	1 × R0.02 × 2	45	1	7.6	0.95	11.19°	4	3	2.06	2.14	2.21	2.29	2.48	1	A	●	8,930
8557696	1 × R0.02 × 3			8.6		9.92°			3.1	3.21	3.32	3.44	3.72			●	9,360
8557697	1 × R0.1 × 2			7.6		11.3°			2.06	2.13	2.2	2.28	2.46			●	8,930
8557698	1 × R0.1 × 3			8.6		10°			3.1	3.2	3.31	3.43	3.7			●	9,040
8557699	1 × R0.1 × 4			9.6		8.97°			4.13	4.27	4.42	4.58	4.95			●	9,100
8557700	1 × R0.1 × 5			10.6		8.13°			5.16	5.34	5.53	5.73	6.19			●	9,360
8557701	1 × R0.1 × 6			11.6		7.43°			6.2	6.41	6.64	6.88	7.43			●	9,520
8557702	1 × R0.1 × 8			13.6		6.34°			8.26	8.55	8.85	9.18	9.92			●	9,690
8557703	1 × R0.1 × 10			15.6		5.53°			10.33	10.69	11.07	11.48	12.41			●	9,920
8557704	1 × R0.2 × 2			7.6		11.43°			2.06	2.12	2.19	2.27	2.44			●	8,930
8557705	1 × R0.2 × 3			8.6		10.11°			3.09	3.19	3.3	3.42	3.68			●	9,040
8557706	1 × R0.2 × 4			9.6		9.06°			4.13	4.26	4.41	4.57	4.92			●	9,100
8557707	1 × R0.2 × 5	10.6	8.2°	5.16	5.33	5.52	5.72	6.17	●	9,360							
8557708	1 × R0.2 × 6	11.6	7.49°	6.19	6.4	6.63	6.87	7.41	●	9,520							
8557709	1 × R0.2 × 8	13.6	6.39°	8.26	8.54	8.84	9.17	9.9	●	9,690							
8557710	1 × R0.2 × 10	15.6	5.56°	10.33	10.68	11.06	11.47	12.38	●	9,920							
8557711	1 × R0.3 × 2	7.6	11.57°	2.06	2.12	2.18	2.25	2.41	●	8,930							
8557712	1 × R0.3 × 3	8.6	10.22°	3.09	3.19	3.29	3.4	3.66	●	9,040							

● = 標準在庫品 ● = Standard stock item

NEXT



# AE-CPR-N

CARBIDE **DLC-KUSS**  $\pm 0.004$   $R$  SHANK **h4** SHRINK **FIT** **38°** SPEED FEED **P19~P21**

DC  $\leq 1$  0~-0.006  
1 < DC 0~-0.01

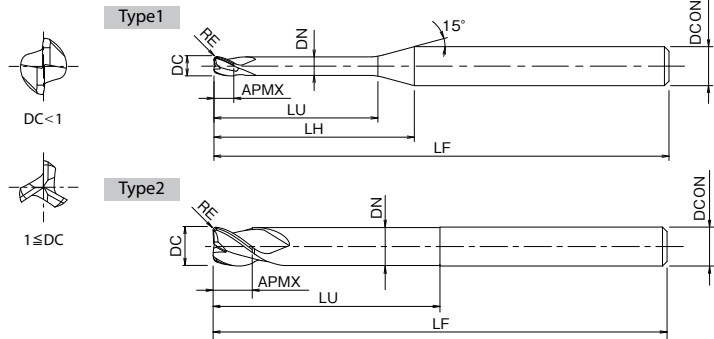

コーティングに色むらが発生する場合がありますが、性能上は全く問題ありません。

End mills may have some discoloration, but it does not cause any performance problems.

**FROM**

単位:mm Unit:mm

ツールNo. EDP No.	外径×コーナ半径×首下長 DC × RE × LU	全長 LF	刃長 APMX	LH	首径 DN	干渉角度 $\theta_k$	シャンク径 DCON	刃数 ZEPF	ワーク勾配角 $\alpha$ に対する実有効長 $L_e$ <sup>注1</sup> Effective length by inclined angles					形状 Type	在庫 Stock	標準価格 (Yen)	
									0.5°	1°	1.5°	2°	3°				
8557713	1.5 × R0.3 × 3	45	1.5	7.8	1.45	9.48°	4	3	3.15	3.28	3.4	3.52	3.78	1	A	●	9,360
8557714	1.5 × R0.5 × 3			7.8		9.71°			3.14	3.27	3.38	3.49	3.73			●	9,360
8557715	1.5 × R0.5 × 10			14.8		5°			10.42	10.77	11.14	11.54	12.43			●	9,520
8557716	1.5 × R0.5 × 12			16.8		4.39°			12.49	12.91	13.35	13.84	14.92			●	9,580
8557717	1.5 × R0.5 × 20			24.8		2.95°			20.76	21.46	22.22	23.04	—			●	9,760
8557718	2 × R0.1 × 4	50	2	8.2	1.95	7.07°	4	3	4.28	4.55	4.79	5.03	5.48	1	A	●	8,690
8557719	2 × R0.1 × 6			10.2		5.68°			6.41	6.76	7.08	7.37	7.97			●	8,770
8557720	2 × R0.1 × 8			12.2		4.74°			8.52	8.95	9.32	9.67	10.45			●	9,100
8557721	2 × R0.1 × 10			14.2		4.07°			10.63	11.12	11.54	11.97	12.94			●	9,170
8557722	2 × R0.1 × 15			19.2		3.01°			15.87	16.49	17.09	17.72	19.15			●	9,260
8557723	2 × R0.1 × 16			20.2		2.86°			16.91	17.56	18.19	18.87	—			●	9,360
8557724	2 × R0.1 × 20			24.2		2.38°			21.08	21.84	22.63	23.47	—			●	9,440
8557725	2 × R0.2 × 4			8.2		7.15°			4.28	4.53	4.78	5.01	5.46			●	8,690
8557726	2 × R0.2 × 10			14.2		4.1°			10.62	11.11	11.53	11.96	12.91			●	9,170
8557727	2 × R0.2 × 16			20.2		2.87°			16.91	17.56	18.18	18.86	—			●	9,360
8557728	2 × R0.2 × 20	24.2	2.39°	21.08	21.84	22.62	23.46	—	●	9,440							
8557729	2 × R0.3 × 4	8.2	7.24°	4.27	4.52	4.76	4.99	5.43	●	8,690							
8557730	2 × R0.3 × 6	10.2	5.79°	6.39	6.74	7.05	7.34	7.92	●	8,770							
8557731	2 × R0.3 × 8	12.2	4.82°	8.51	8.93	9.3	9.64	10.4	●	9,100							
8557732	2 × R0.3 × 10	14.2	4.13°	10.62	11.1	11.52	11.94	12.89	●	9,170							
8557733	2 × R0.3 × 15	19.2	3.04°	15.86	16.48	17.06	17.69	19.11	●	9,260							
8557734	2 × R0.3 × 16	20.2	2.89°	16.9	17.55	18.17	18.84	—	●	9,360							
8557735	2 × R0.3 × 20	24.2	2.4°	21.07	21.83	22.61	23.44	—	●	9,440							
8557736	2.5 × R0.5 × 5	55	2.5	8.1	2.4	5.61°	4	3	5.28	5.54	5.79	6.03	6.49	1	A	●	9,040
8557737	2.5 × R0.5 × 20			23.1		1.9°			20.97	21.7	22.46	—	—			●	9,440
8557738	3 × R0.2 × 6	55	3	11.8	2.85	7.34°	6	3	6.31	6.6	6.88	7.14	7.7	1	A	●	9,690
8557739	3 × R0.2 × 12			17.8		4.86°			12.59	13.07	13.54	14.04	15.16			●	9,920
8557740	3 × R0.2 × 18			23.8		3.64°			18.83	19.49	20.19	20.94	22.62			●	10,200
8557741	3 × R0.2 × 21			26.8		3.23°			21.94	22.7	23.51	24.39	26.35			●	10,600
8557742	3 × R0.2 × 24			29.8		2.9°			25.04	25.91	26.84	27.84	—			●	10,900
8557743	3 × R0.3 × 6	11.8	7.4°	6.31	6.6	6.87	7.12	7.68	●	9,690							
8557744	3 × R0.3 × 8	13.8	6.32°	8.4	8.77	9.09	9.42	10.17	●	9,760							
8557745	3 × R0.3 × 12	17.8	4.89°	12.58	13.07	13.53	14.02	15.14	●	9,920							
8557746	3 × R0.3 × 20	25.8	3.37°	20.9	21.62	22.39	23.22	25.08	●	10,300							
8557747	3 × R0.5 × 6	11.8	7.52°	6.3	6.58	6.84	7.1	7.63	●	9,690							
8557748	3 × R0.5 × 12	17.8	4.94°	12.57	13.05	13.51	13.99	15.09	●	9,920							
8557749	3 × R0.5 × 15	20.8	4.22°	15.7	16.26	16.83	17.44	18.82	●	10,200							
8557750	3 × R0.5 × 18	23.8	3.68°	18.82	19.47	20.16	20.89	22.55	●	10,200							
8557751	3 × R0.5 × 21	26.8	3.26°	21.93	22.68	23.48	24.34	26.28	●	11,300							
8557752	3 × R0.5 × 25	30.8	2.83°	26.07	26.96	27.91	28.94	—	●	11,500							
8557753	3 × R0.5 × 30	35.8	2.43°	31.24	32.31	33.46	34.69	—	●	11,800							

・アイコンの説明はp.8をご覧ください。 See p.8 for explanation of icons.

● = 標準在庫品 ● = Standard stock item



注1: ワーク勾配角 $\alpha$ に対する実有効長  $L_e$  欄に数値がないものは干渉無しを表します  
 Note: If there is no value in the actual effective length ( $L_e$  column) for the work gradient angle  $\alpha$ , it indicates no interference.

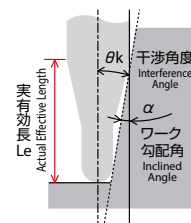

FROM

単位:mm Unit:mm

ツールNo. EDP No.	外径×コーナ半径×首下長 DC×RE×LU	全長 LF	刃長 APMX	LH	首径 DN	干渉角度 $\theta_k$	シャンク径 DCON	刃数 ZEPF	ワーク勾配角 $\alpha$ に対する実有効長 $L_e$ 注1 Effective length by inclined angles					形状 Type	在庫 Stock	標準価格 (Yen)	
									0.5°	1°	1.5°	2°	3°				
8557754	4 × R0.2 × 8	60	4	12	3.85	4.86°	6	3	8.41	8.77	9.11	9.44	10.19	1	A	●	9,690
8557755	4 × R0.2 × 16			20		2.9°			16.75	17.35	17.97	18.64	—			●	9,920
8557756	4 × R0.2 × 20			24		2.41°			20.9	21.63	22.4	23.24	—			●	10,200
8557757	4 × R0.2 × 24			28		2.07°			25.04	25.91	26.84	27.84	—			●	10,200
8557758	4 × R0.2 × 28	75	4	32	1.81°	29.18	30.19	31.27	—	—	●	10,600					
8557759	4 × R0.2 × 32			36	1.61°	33.31	34.47	35.7	—	—	●	10,900					
8557760	4 × R0.3 × 8	60	4	12	4.9°	8.4	8.77	9.09	9.42	10.17	●	9,690					
8557761	4 × R0.3 × 20			24	2.42°	20.9	21.62	22.39	23.22	—	●	10,200					
8557762	4 × R0.5 × 8			12	4.98°	8.39	8.75	9.07	9.4	10.12	●	9,690					
8557763	4 × R0.5 × 12			16	3.7°	12.57	13.05	13.51	13.99	15.09	●	9,850					
8557764	4 × R0.5 × 16	75	4	20	2.94°	16.74	17.33	17.94	18.59	—	●	9,920					
8557765	4 × R0.5 × 20			24	2.44°	20.89	21.61	22.37	23.19	—	●	10,200					
8557766	4 × R0.5 × 24			28	2.09°	25.03	25.89	26.81	27.79	—	●	10,200					
8557767	4 × R0.5 × 25			29	2.02°	26.07	26.96	27.91	28.94	—	●	10,300					
8557768	4 × R0.5 × 28	75	4	32	1.82°	29.17	30.17	31.24	—	—	●	10,600					
8557769	4 × R0.5 × 32			36	1.62°	33.3	34.45	35.67	—	—	●	11,500					
8557770	4 × R1 × 8	60	4	12	5.19°	8.37	8.71	9.02	9.32	10	●	9,690					
8557771	4 × R1 × 16			20	3.02°	16.72	17.3	17.89	18.52	19.95	●	9,920					
8557772	4 × R1 × 24			28	2.13°	25.02	25.85	26.75	27.72	—	●	10,200					
8557773	4 × R1 × 28			75	4	32	1.85°	29.15	30.13	31.19	—	—	●	10,600			
8557774	4 × R1 × 32	36	1.64°			33.29	34.41	35.62	—	—	●	11,500					
8557775	6 × R0.1 × 12	60	6	—	—	—	—	—	—	—	●	11,200					
8557776	6 × R0.1 × 24			—	—	—	—	—	—	—	●	11,500					
8557777	6 × R0.2 × 12			—	—	—	—	—	—	—	●	11,200					
8557778	6 × R0.2 × 24			—	—	—	—	—	—	—	●	11,500					
8557779	6 × R0.2 × 32	80	6	—	—	—	—	—	—	—	●	17,600					
8557780	6 × R0.2 × 48			—	—	—	—	—	—	—	●	17,900					
8557781	6 × R0.5 × 12	60	6	—	5.85	—	6	3	—	—	—	—	●	10,300			
8557782	6 × R0.5 × 24			—	—	—	—	—	—	—	—	—	●	11,500			
8557783	6 × R0.5 × 30			—	—	—	—	—	—	—	—	—	●	12,000			
8557784	6 × R0.5 × 32			—	—	—	—	—	—	—	—	—	●	16,700			
8557785	6 × R0.5 × 48	80	6	—	—	—	—	—	—	—	—	—	●	17,900			
8557786	6 × R1 × 12			—	—	—	—	—	—	—	—	—	●	10,300			
8557787	6 × R1 × 24	60	6	—	—	—	—	—	—	—	—	—	●	11,500			
8557788	6 × R1 × 32			—	—	—	—	—	—	—	—	—	●	16,700			
8557789	6 × R1 × 48	80	6	—	—	—	—	—	—	—	—	●	17,900				

● = 標準在庫品 ● = Standard stock item



# AE-CPR-N 切削条件基準表 Cutting Condition

**⚠** 加工時に発生する火花や破損による発熱で引火・火災の危険があります。  
防火対策を必ず行って下さい。

**Caution:** Sparks generated during operation or heat caused by tool breakage can cause fire.  
Be sure to use all proper fire-prevention measures.

被削材 Work Material			銅 Copper (C1020,C1100)				銅タングステン Copper Tungsten (W70% - Cu30%)				
外径 DC	RE	首下長 LU (mm)	回転速度 Speed (min <sup>-1</sup> )	送り速度 Feed (mm/min)	ap (mm)	ae (mm)	回転速度 Speed (min <sup>-1</sup> )	送り速度 Feed (mm/min)	ap (mm)	ae (mm)	
0.2	R0.05	0.4	40,000	400	0.03	0.06	40,000	360	0.024	0.06	
		0.6	40,000	360	0.024	0.06	40,000	320	0.019	0.06	
		1	40,000	280	0.019	0.06	40,000	250	0.015	0.06	
		1.5	40,000	180	0.015	0.06	40,000	160	0.012	0.06	
0.3	R0.05	0.6	40,000	480	0.03	0.12	40,000	430	0.024	0.12	
		1	40,000	430	0.023	0.12	40,000	380	0.018	0.12	
		1.5	40,000	360	0.019	0.12	40,000	320	0.015	0.12	
		2	40,000	290	0.016	0.12	40,000	260	0.013	0.12	
0.4	R0.02	0.8	40,000	640	0.01	0.22	40,000	580	0.008	0.22	
		2	40,000	520	0.006	0.22	35,000	410	0.005	0.22	
	R0.05	0.8	40,000	640	0.03	0.18	40,000	580	0.024	0.18	
		1.2	40,000	600	0.024	0.18	40,000	540	0.019	0.18	
		2	40,000	520	0.019	0.18	35,000	410	0.015	0.18	
		3	30,000	370	0.015	0.18	25,000	300	0.012	0.18	
	R0.1	4	25,000	240	0.013	0.18	20,000	190	0.01	0.18	
		0.8	40,000	640	0.06	0.12	40,000	580	0.048	0.12	
		1.2	40,000	600	0.049	0.12	40,000	540	0.039	0.12	
		2	40,000	520	0.038	0.12	35,000	410	0.03	0.12	
	0.5	R0.05	3	30,000	370	0.031	0.12	25,000	300	0.025	0.12
			4	25,000	240	0.027	0.12	20,000	190	0.022	0.12
1			40,000	880	0.03	0.24	40,000	790	0.024	0.24	
2			40,000	770	0.023	0.24	35,000	690	0.018	0.24	
3			35,000	650	0.019	0.24	30,000	510	0.015	0.24	
R0.1		4	30,000	540	0.017	0.24	25,000	420	0.014	0.24	
		5	25,000	370	0.016	0.24	20,000	300	0.013	0.24	
		1	40,000	880	0.06	0.18	40,000	790	0.048	0.18	
		2	40,000	770	0.045	0.18	35,000	690	0.036	0.18	
		3	35,000	650	0.039	0.18	30,000	510	0.031	0.18	
0.6	R0.05	4	30,000	540	0.034	0.18	25,000	420	0.027	0.18	
		5	25,000	370	0.032	0.18	20,000	300	0.026	0.18	
		1.2	40,000	1,120	0.03	0.3	35,000	880	0.024	0.3	
		2	37,000	1,030	0.024	0.3	35,000	810	0.019	0.3	
	R0.1	4	29,000	710	0.019	0.3	26,000	580	0.015	0.3	
		6	22,000	440	0.016	0.3	20,000	280	0.013	0.3	
		1.2	40,000	1,120	0.06	0.24	35,000	880	0.048	0.24	
		2	37,000	1,030	0.049	0.24	35,000	810	0.039	0.24	
		3	33,000	800	0.042	0.24	30,000	660	0.034	0.24	
		4	29,000	710	0.037	0.24	26,000	580	0.03	0.24	
R0.2	6	22,000	440	0.032	0.24	20,000	280	0.026	0.24		
	1.2	40,000	1,120	0.12	0.12	35,000	880	0.096	0.12		
0.8	R0.05	4	29,000	710	0.074	0.12	26,000	580	0.059	0.12	
		1.6	36,000	1,580	0.03	0.42	32,000	1,270	0.024	0.42	
		4	30,000	1,390	0.021	0.42	27,000	1,010	0.017	0.42	
		6	25,000	1,000	0.018	0.42	23,000	800	0.014	0.42	
	R0.1	8	20,000	750	0.016	0.42	18,000	620	0.013	0.42	
		1.6	36,000	1,580	0.06	0.36	32,000	1,270	0.048	0.36	
		4	30,000	1,240	0.042	0.36	27,000	1,010	0.034	0.36	
		6	25,000	1,000	0.035	0.36	23,000	800	0.028	0.36	
8	20,000	750	0.032	0.36	18,000	620	0.026	0.36			

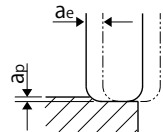

1. 機械、ホルダは剛性のある精度の高いものをご使用下さい。
2. 切込深さ、機械剛性等使用状況により、回転速度、送り速度を調整ください。
3. 水溶性切削油剤をご使用下さい。
4. 加工面、精度を重視される場合は、不水溶性切削油剤をご使用ください。切込深さ、送り速度を必要に応じて調整下さい。
5. 切削油剤は切削油剤メーカーの推奨するものを必ずご使用下さい。加工物が変色することがあります。

**NEXT**



FROM

被削材 Work Material			銅 Copper (C1020,C1100)				銅タングステン Copper Tungsten (W70% - Cu30%)				
外径 DC	RE	首下長 LU (mm)	回転速度 Speed (min <sup>-1</sup> )	送り速度 Feed (mm/min)	ap (mm)	ae (mm)	回転速度 Speed (min <sup>-1</sup> )	送り速度 Feed (mm/min)	ap (mm)	ae (mm)	
1	R0.02	2	32,000	2,880	0.01	0.6	29,000	2,350	0.008	0.6	
		3	30,000	2,690	0.009	0.6	27,000	2,180	0.007	0.6	
	R0.1	2	32,000	2,880	0.06	0.5	29,000	2,350	0.05	0.5	
		3	30,000	2,690	0.053	0.5	27,000	2,180	0.042	0.5	
		4	28,000	2,500	0.049	0.5	25,000	1,940	0.039	0.5	
		5	27,000	2,240	0.046	0.5	24,000	1,800	0.037	0.5	
		6	25,000	2,070	0.043	0.5	23,000	1,650	0.034	0.5	
		8	21,000	1,740	0.04	0.5	19,000	1,440	0.032	0.5	
		10	18,000	1,390	0.037	0.5	16,000	1,130	0.03	0.5	
	R0.2	2	32,000	2,880	0.12	0.4	29,000	2,350	0.1	0.4	
		3	30,000	2,690	0.11	0.4	27,000	2,180	0.08	0.4	
		4	28,000	2,500	0.1	0.4	25,000	1,940	0.08	0.4	
		5	27,000	2,240	0.09	0.4	24,000	1,800	0.07	0.4	
		6	25,000	2,070	0.09	0.4	23,000	1,650	0.07	0.4	
		8	21,000	1,740	0.08	0.4	19,000	1,440	0.06	0.4	
	R0.3	2	32,000	2,880	0.2	0.3	29,000	2,350	0.16	0.3	
		3	30,000	2,690	0.18	0.3	27,000	2,180	0.14	0.3	
	1.5	R0.3	3	22,000	2,970	0.12	0.6	20,000	2,410	0.1	0.6
		R0.5	3	22,000	2,970	0.3	0.3	20,000	2,410	0.24	0.3
			10	16,000	2,030	0.21	0.3	14,000	1,650	0.17	0.3
12			15,000	1,810	0.2	0.3	14,000	1,470	0.16	0.3	
20			8,000	1,060	0.17	0.3	7,000	860	0.14	0.3	
2	R0.1	4	17,500	3,150	0.06	1.1	16,000	2,560	0.048	1.1	
		6	16,500	2,930	0.054	1.1	15,000	2,370	0.043	1.1	
		8	15,500	2,630	0.05	1.1	14,000	2,130	0.04	1.1	
		10	14,500	2,420	0.048	1.1	13,000	1,970	0.038	1.1	
		15	12,000	1,910	0.043	1.1	11,000	1,550	0.034	1.1	
		16	11,500	1,790	0.042	1.1	10,500	1,460	0.034	1.1	
		20	9,500	1,460	0.04	1.1	8,500	1,190	0.032	1.1	
	R0.2	4	17,500	3,150	0.12	1	16,000	2,560	0.1	1	
		10	14,500	2,420	0.1	1	13,000	1,970	0.08	1	
		16	11,500	1,790	0.09	1	10,500	1,460	0.07	1	
		20	9,500	1,460	0.08	1	8,500	1,190	0.06	1	
	R0.3	4	17,500	3,150	0.2	0.9	16,000	2,560	0.16	0.9	
		6	16,500	2,930	0.18	0.9	15,000	2,370	0.14	0.9	
		8	15,500	2,630	0.17	0.9	14,000	2,130	0.13	0.9	
		10	14,500	2,420	0.16	0.9	13,000	1,970	0.13	0.9	
		15	12,000	1,910	0.14	0.9	11,000	1,550	0.12	0.9	
		16	11,500	1,790	0.14	0.9	10,500	1,460	0.11	0.9	
		20	9,500	1,460	0.13	0.9	8,500	1,190	0.11	0.9	
	2.5	R0.5	5	15,000	3,600	0.3	0.9	13,500	2,920	0.24	0.9
			20	11,500	2,040	0.21	0.9	10,500	1,660	0.17	0.9

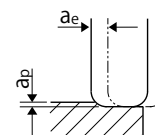

1. Use a rigid and precise machine and holder.
2. Please adjust the speed and feed when the cutting depth is large or when machines with low rigidity are used.
3. Use a water soluble fluid.
4. Use a non-water-soluble cutting fluid if the machined surface and accuracy are of critical importance.  
Adjust the depth of cut and feed rate as necessary.
5. Always use a cutting fluid recommended by the cutting fluid manufacturer as the workpiece may discolor.

NEXT



# AE-CPR-N 切削条件基準表 Cutting Condition

**!** 加工時に発生する火花や破損による発熱で引火・火災の危険があります。  
防火対策を必ず行って下さい。

Caution : Sparks generated during operation or heat caused by tool breakage can cause fire.  
Be sure to use all proper fire-prevention measures.

**FROM**

被削材 Work Material			銅 Copper (C1020,C1100)				銅タングステン Copper Tungsten (W70% - Cu30%)				
外径 DC	RE	首下長 LU (mm)	回転速度 Speed (min <sup>-1</sup> )	送り速度 Feed (mm/min)	ap (mm)	ae (mm)	回転速度 Speed (min <sup>-1</sup> )	送り速度 Feed (mm/min)	ap (mm)	ae (mm)	
3	R0.2	6	12,500	3,750	0.12	1.6	11,500	3,050	0.1	1.6	
		12	11,500	3,190	0.1	1.6	10,500	2,600	0.08	1.6	
		18	10,500	2,680	0.1	1.6	9,500	2,180	0.08	1.6	
		21	10,000	2,440	0.09	1.6	9,000	1,970	0.07	1.6	
		24	9,500	2,210	0.09	1.6	8,500	1,800	0.07	1.6	
	R0.3	6	12,500	3,750	0.2	1.5	11,500	3,050	0.16	1.5	
		8	12,000	3,510	0.19	1.5	11,000	2,840	0.15	1.5	
		12	11,500	3,190	0.17	1.5	10,500	2,600	0.14	1.5	
		20	10,500	2,600	0.16	1.5	9,500	2,120	0.13	1.5	
	R0.5	6	12,500	3,750	0.3	1.2	11,500	3,050	0.24	1.2	
		12	11,500	3,190	0.26	1.2	10,500	2,600	0.21	1.2	
		15	11,000	2,930	0.25	1.2	10,000	2,370	0.2	1.2	
		18	10,500	2,680	0.24	1.2	9,500	2,180	0.19	1.2	
		21	10,000	2,440	0.23	1.2	9,000	1,970	0.19	1.2	
		25	9,500	2,170	0.23	1.2	8,500	1,770	0.18	1.2	
	4	R0.2	8	9,500	3,710	0.12	2.2	8,600	3,020	0.1	2.2
			16	8,800	3,220	0.1	2.2	7,900	2,600	0.08	2.2
			20	8,500	3,000	0.1	2.2	7,700	2,450	0.08	2.2
24			8,100	2,760	0.1	2.2	7,300	2,240	0.08	2.2	
28			7,700	2,530	0.09	2.2	6,900	2,040	0.07	2.2	
32			7,400	2,350	0.09	2.2	6,700	1,910	0.07	2.2	
R0.3		8	9,500	3,710	0.2	2.1	8,600	3,020	0.16	2.1	
		20	8,400	2,970	0.17	2.1	7,600	2,420	0.13	2.1	
R0.5		8	9,500	3,710	0.3	1.8	8,600	3,020	0.24	1.8	
		12	9,100	3,440	0.28	1.8	8,200	2,790	0.22	1.8	
		16	8,800	3,220	0.26	1.8	7,900	2,600	0.21	1.8	
		20	8,400	2,970	0.25	1.8	7,600	2,420	0.2	1.8	
		24	8,100	2,760	0.24	1.8	7,300	2,240	0.19	1.8	
		25	8,000	2,710	0.24	1.8	7,200	2,190	0.19	1.8	
		28	7,700	2,530	0.23	1.8	6,900	2,040	0.19	1.8	
		32	7,400	2,350	0.23	1.8	6,700	1,910	0.18	1.8	
R1		8	9,500	3,710	0.6	1.2	8,600	3,020	0.48	1.2	
		16	8,800	3,220	0.52	1.2	7,900	2,600	0.42	1.2	
	24	8,100	2,760	0.48	1.2	7,300	2,240	0.39	1.2		
	28	7,700	2,530	0.47	1.2	6,900	2,040	0.37	1.2		
	32	7,400	2,350	0.46	1.2	6,700	1,910	0.36	1.2		
6	R0.1	12	6,500	3,900	0.06	3.5	5,900	3,190	0.05	3.5	
		24	6,000	3,380	0.05	3.5	5,400	2,730	0.04	3.5	
	R0.2	12	6,500	3,900	0.12	3.4	5,900	3,190	0.1	3.4	
		24	6,000	3,380	0.1	3.4	5,400	2,730	0.08	3.4	
		32	5,700	3,060	0.1	3.4	5,100	2,470	0.08	3.4	
		48	5,000	2,440	0.09	3.4	4,500	1,980	0.07	3.4	
	R0.5	12	6,500	3,900	0.3	3	5,900	3,190	0.24	3	
		24	6,000	3,380	0.26	3	5,400	2,730	0.21	3	
		30	5,800	3,150	0.25	3	5,200	2,550	0.2	3	
		32	5,700	3,060	0.25	3	5,100	2,470	0.2	3	
	R1	12	6,500	3,900	0.6	2.4	5,900	3,190	0.48	2.4	
		24	6,000	3,380	0.52	2.4	5,400	2,730	0.42	2.4	
32		5,700	3,060	0.49	2.4	5,100	2,470	0.39	2.4		
48		5,000	2,440	0.46	2.4	4,500	1,980	0.36	2.4		

1. 機械、ホルダは剛性のある精度の高いものをご使用下さい。
  2. 切込深さ、機械剛性等使用状況により、回転速度、送り速度を調整ください。
  3. 水溶性切削油剤をご使用下さい。
  4. 加工面、精度を重視される場合は、不水溶性切削油剤をご使用ください。切込深さ、送り速度を必要に応じて調整下さい。
  5. 切削油剤は切削油剤メーカーの推奨するものをご使用下さい。加工物が変色することがあります。
1. Use a rigid and precise machine and holder.
  2. Please adjust the speed and feed when the cutting depth is large or when machines with low rigidity are used.
  3. Use a water soluble fluid.
  4. Use a non-water-soluble cutting fluid if the machined surface and accuracy are of critical importance. Adjust the depth of cut and feed rate as necessary.
  5. Always use a cutting fluid recommended by the cutting fluid manufacturer as the workpiece may discolor.

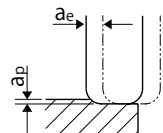

# オーエスジーは環境に優しい取り組みを推進しています

OSG's Environmental Initiatives

## 再研磨・再コーティング

### Tool Reconditioning

使用できなくなった工具を蘇らせ再利用することは、省資源化と地球環境の保護活動への貢献につながります。

Tool reconditioning contributes to resource conservation by bringing worn cutting tools back to life, which is environmentally friendly and sustainable.



## 超硬リサイクル

### Carbide Recycling

再研磨できなくなった超硬工具は日本ハードメタルで「超硬リサイクル」することが可能です。

超硬リサイクルは、希少金属のレアメタルを多く含む超硬材料の使用量を減らすことができ、環境保護に役立ちます。

Carbide tools that can no longer be reground can be recycled through Nihon Hard Metal's carbide recycling program. Cemented carbide materials contain a large amount of rare metals. Carbide recycling reduces material consumption and contributes to environmental preservation.

### 日本ハードメタル「超硬リサイクル」の特長 Highlights of Nihon Hard Metal's "Carbide Recycling" Program

超硬工具であれば、  
エンドミル・ドリル・リーマ・  
チップ等の分別は不要

As long as the tool has been hardened, it doesn't have to be separated into categories such as end mills, drills, reamers, and tips.

多少の異材質工具が混入もOK

(サーメット、セラミック、  
または鋼材シャンク付きのものは選別)

Tools that contain a small amount of different materials are accepted (tools with cermet, ceramic and steel shanks are separated)

1回あたりの回収量：20kg～

(送料は日本ハードメタルにて負担・  
宅配便等着払い)

Amount of material that can be sent for recycling :  
20kg and over (shipping costs are paid by Nihon Hard Metal Co., Ltd.)

リサイクル料金：  
振り込みにて対応

Recycling payment :  
by direct bank deposit





shaping your dreams

本社 〒442-8543 愛知県豊川市本野ケ原三丁目22番地 TEL(0533)82-1111 E-mail: cs-info@osg.co.jp Web: https://www.osg.co.jp/

International Headquarters 3-22 Honnogahara, Toyokawa, Aichi, 442-8543, JAPAN TEL: +81-533-82-1118 FAX: +81-533-82-1136

東日本営業部 〒140-0002 東京都品川区東品川4-12-6 品川シーサイドキャナルタワー 19階 TEL(03)5715-2966

西日本営業部 〒550-0013 大阪府大阪市西区新町2-4-2 405号 TEL(06)6538-3880

アプリケーション営業部 〒451-0051 愛知県名古屋市中区則武新町3-1-17 BIZrium名古屋 4階 TEL(052)589-8320

仙台 TEL (022) 390-9701  
郡山 TEL (024) 991-7485  
茨城 TEL (029) 354-7017  
両毛 TEL (0270) 40-5855  
宇都宮 TEL (028) 651-2720  
新潟 TEL (025) 288-3888  
東京 TEL (03) 5715-2966  
八王子 TEL (042) 645-5406  
厚木 TEL (046) 230-5030  
諏訪 TEL (0266) 58-0152  
上田 TEL (0268) 28-7381  
静岡 TEL (054) 283-6651  
浜松 TEL (053) 461-1121  
豊川 TEL (0533) 82-1145

三河 TEL (0566) 62-8286  
トヨタ TEL (0533) 82-1145  
名古屋 TEL (052) 589-8320  
岐阜 TEL (058) 259-6055  
京滋 TEL (077) 553-2012  
大阪 TEL (06) 4308-3411  
明石 TEL (078) 927-8212  
金沢 TEL (076) 268-0830  
岡山 TEL (086) 241-0411  
広島 TEL (082) 532-6808  
四国 TEL (087) 868-4003  
九州 TEL (092) 504-1211  
北九州 TEL (093) 922-8190  
熊本 TEL (096) 386-5120

〈工具の技術的なご相談は…〉 コミュニケーションダイヤル

よ い 工 具 は 一 番

0120-41-5981 土日祝日、会社休日を除く

コミュニケーション FAX 0533-82-1134 コミュニケーションE-mail hp-info@osg.co.jp

安全にお使いいただくために

- 工具を使用する時は、破損する危険があるので、必ずカバー・保護眼鏡・安全靴等を使用して下さい。
- 切れ刃は素手で触らないで下さい。
- 切りくずは素手で触らないで下さい。
- 工具の切れ味が悪くなったら使用を中止して下さい。
- 異常音・異常振動が発生したら、直ちに使用を中止して下さい。
- 工具には手を加えないで下さい。
- 加工前に工具の寸法確認を行って下さい。

Safe use of cutting tools

- Use safety cover, safety glasses and safety shoes during operation.
- Do not touch cutting edges with bare hands.
- Do not touch cutting chips with bare hands. Chips will be hot after cutting.
- Stop cutting when the tool becomes dull.
- Stop cutting operation immediately if you hear any abnormal cutting sounds.
- Do not modify tools.
- Please use appropriate tools for the operation. Check dimensions to ensure proper selection.

OSG代理店

Copyright ©2021 OSG Corporation. All rights reserved.

- 製品については、常に研究・改良を行っておりますので、予告なく本カタログ掲載仕様を変更する場合があります。 Tool specifications are subject to change without notice.
- 本書掲載内容の無断転載・複製を禁じます。

N-133.419.AF.FD(DN) 24.01

オーエスジー株式会社

